

SANI-TECH[®]



“THE AUGER IS THE ANSWER”

MODEL SC1040/30

HIGH DENSITY SELF-CONTAINED COMPACTOR



SANI-TECH AUGERS
DO IT ALL

SANI-TECH augers pre-crush and compact in one powerful motion. While processing material, augers continuously runs in a forward direction, crushing and reducing the size of what they're fed. This enables them to compact up to five times faster than conventional hydraulic compactors.

Sani-Tech SC1040/30 10HP Self-Contained compactors are ideal for wet, hazardous or messy waste and where cleanliness and sanitation are the highest priority. They outperform the competition because they:

- Are 100% sealed to prevent liquid and trash spillage during daily operation and emptying.
- Are designed and engineered for high performance and dependable service.
- Use 40" to 30" tapered augers designed to pre-crush large and bulky trash.
- Allow operators to simply throw material into the hopper, start the compactor and walk away. No wait time, no human intervention.
- Utilize all electric drive systems that run clean and quiet.
- Obtain compaction ratios that are two to three times greater than standard hydraulic compactors to better maximize savings.
- Have inherently small footprints so they can be installed in tight spaces.
- Have a wide variety of optional features to choose from.

COST SAVINGS IS THE BOTTOM LINE

**Substantial reductions in operating costs are obtained by:
increased compaction, reduced hauls and labor savings.**

SANI-TECH SYSTEMS • PO BOX 444 • DUVALL, WA 98019 • (425) 788-6444 • FAX (425) 844-8625

SELF-CONTAINED COMPACTOR MODEL SC1040/30

SPECIFICATIONS

Hopper Capacity:	4.5 Cubic Yards
Bi-fold Door Size:	36"W X 30"H
Auger Diameter:	Tapered 40" to 30"
Auger RPM:	8
Motor:	10 HP
Displacement Rate:	270 cu. yds./hr.
Electrical:	240v/480v - 3 phase
Amperage:	30a / 15a
Drive:	Electro-mechanical
Control Panel:	UL listed 110 volt
Compactor Weight:	4100#
Auger Torque:	204,000 In. Lbs.

DIMENSIONS

Model/ Cu. Yd.	Overall Length	Tare Weight
SC1040/30-15	15' - 0"	6,600 lbs.
SC1040/30-20	18' - 0"	7,200 lbs.
SC1040/30-25	21' - 0"	7,900 lbs.
SC1040/30-30*	24' - 0"	8,400 lbs.
SC1040/30-35*	26' - 0"	9,000 lbs.

For special orders consult factory.

* Request prior confirmation with refuse hauler regarding length of this unit.

Specifications are subject to change without notice to accommodate design improvements.

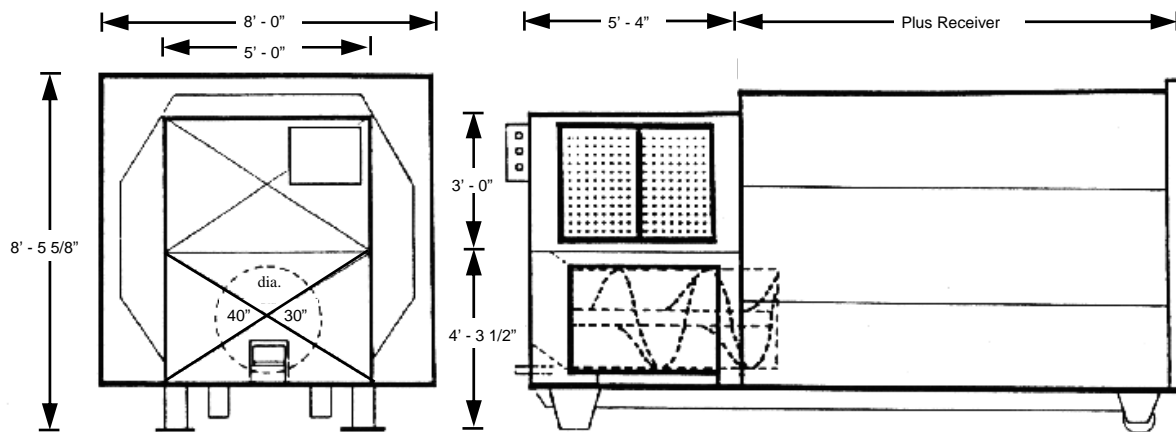

STANDARD FEATURES

- ◆ Abrasion Resistant Alloy Steel Auger
- ◆ Replaceable Cast Auger End Wear Plate
- ◆ Adjustable Running Time
- ◆ Bin Near Full Indicator
- ◆ "Almond" Machinery Enamel Finish
- ◆ Liquid Tight Auger Chamber
- ◆ Adjustable Compaction Density
- ◆ Safety Interlock System
- ◆ Keylock Start/Reverse Switch
- ◆ Mushroom Stop Switch
- ◆ High Performance Roller Bearing System

OPTIONAL FEATURES

- ◆ Odor / Insect Control
- ◆ Cart Dumper
- ◆ Custom Paint Colors
- ◆ Exhaust Fans
- ◆ Fire Suppression Systems
- ◆ Custom Hood Designs
- ◆ Liquid Drain System
- ◆ Bin Gone Sensor
- ◆ Photo Eye Automatic Start
- ◆ Automatic Electric Lubrication System

Consult factory for any custom design work.

3hp to 40hp models available for additional applications.



DEALER:

PO Box 444, Duvall, WA 98019
 (425) 788-6444, Fax: (425) 844-8625
 E-mail: compactorinfo@sanitech.net
 WWW: www.sanitech.net