

# **SANI-TECH**

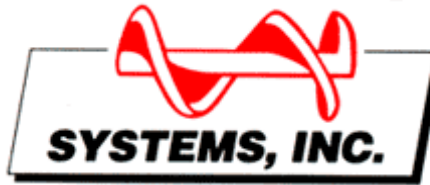

**“THE AUGER IS THE ANSWER”**

**MODEL ST524**

**STATIONARY COMPACTOR**



**SANI-TECH AUGER  
DOES IT ALL**

*SANI-TECH* augers pre-crush and compact in one powerful motion. While processing material, the auger continuously runs in a forward direction, crushing and reducing the size of what it is fed. This enables it to compact up to five times faster than conventional hydraulic compactors.

The Sani-Tech Model ST524 5HP auger compactor is ideal for the types of waste and recyclables generated by:

- Banks • Cinemas • Multi Family Dwellings • Office Buildings
- Restaurants • Retail Stores • Schools • Shopping Malls
- Any applications where space is a prime concern.

With the Sani-Tech auger compactor all you have to do is throw the material into the compactor, turn it on and walk away. When you return, the material will be safely processed into a receiver bin and the compactor will be ready for more.

**COST SAVINGS IS THE BOTTOM LINE**

Substantial reductions in operating costs are obtained by:  
increased compaction, labor savings and reduced hauls.

# STATIONARY COMPACTOR MODEL ST524

SPECIFICATIONS	
Hopper Capacity:	1.8 Cubic Yards
Bi-fold Door Size:	36" W X 30" H
Auger Diameter:	24"
Auger RPM:	8.5
Motor:	5 HP
Displacement Rate:	100 cu. yds./hr.
Electrical:	240v/480v - 3 Phase
Amperage:	20a / 10a
Drive:	electro-mechanical
Control Panel:	UL listed 110 volt
Weight:	1800#
Auger Torque:	70,000 In. Lbs.

Specifications are subject to change without notice to accommodate design improvements.

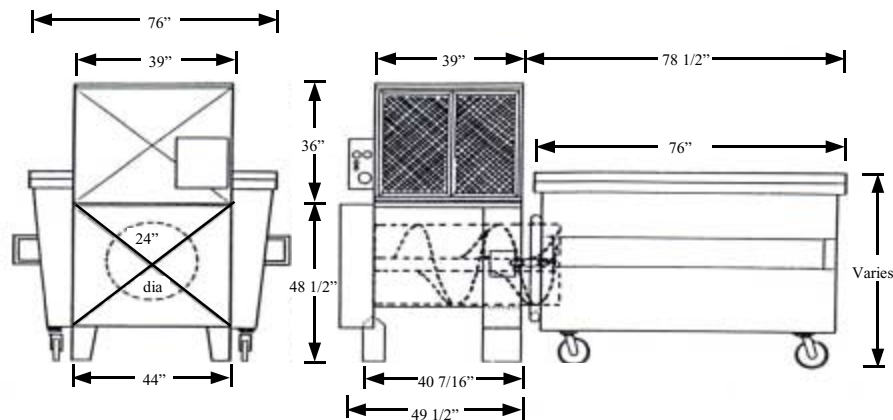

## STANDARD FEATURES

- ◆ Abrasion Resistant Alloy Steel Auger
- ◆ Replaceable Cast Auger End Wear Plate
- ◆ Adjustable Running Time
- ◆ Bin Near Full Indicator
- ◆ "Almond" Machinery Enamel Finish
- ◆ Liquid Tight Auger Chamber
- ◆ Adjustable Compaction Density
- ◆ Safety Interlock System
- ◆ Keylock Start/Reverse Switch
- ◆ Mushroom Stop Switch
- ◆ Electric Lubrication System

## OPTIONAL FEATURES

- ◆ Odor / Insect Control
- ◆ Cart Dumper
- ◆ Custom Paint Colors
- ◆ Exhaust Fans
- ◆ Fire Suppression Systems
- ◆ Custom Hood Designs
- ◆ Liquid Drain System
- ◆ Bin Gone Sensor
- ◆ Photo Eye Automatic Start

*Consult factory for any custom design work.*

5hp to 40hp models available for additional applications.

**SANI-TECH®**

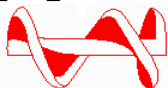

**SYSTEMS, INC.**

DEALER:

P.O. Box 444 Duvall, WA. 98019  
(425) 788-6444 Fax: (425) 844-8625  
E-Mail: [compactorinfo@sanitech.net](mailto:compactorinfo@sanitech.net)  
Web Site: [sanitech.net](http://sanitech.net)