

SANI-TECH

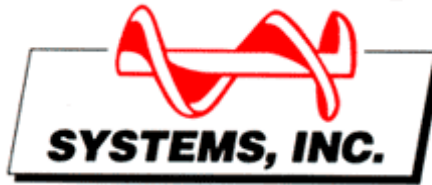

“THE AUGER IS THE ANSWER”

MODEL ST4060/36

HIGH CAPACITY STATIONARY PRE-CRUSHER / COMPACTOR

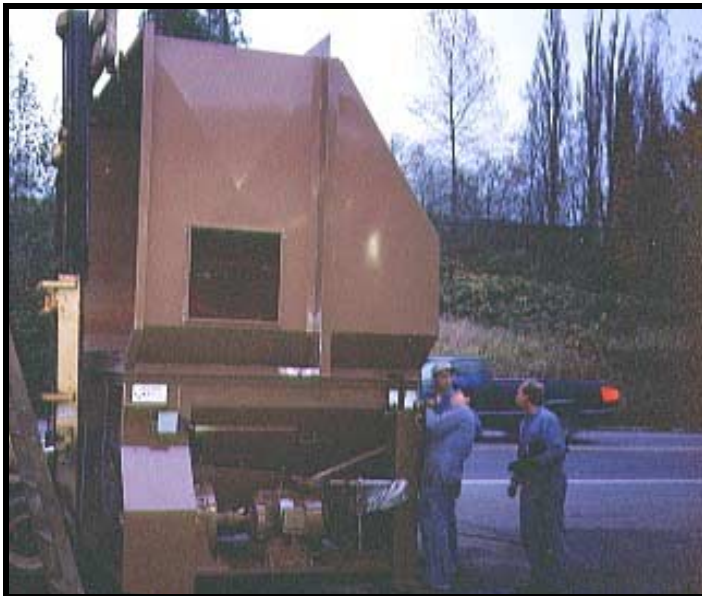

**SANI-TECH AUGER
DOES IT ALL**

SANI-TECH augers pre-crush and compact in one powerful motion. The auger continuously runs in a forward direction, while crushing and reducing the size of what it is fed. This enables it to compact up to five times faster than conventional hydraulic compactors without the expense of purchasing a separate precrusher.

This Sani-Tech Model ST4060/35 40HP super heavy-duty auger compactor is ideal for the types of waste and recyclables generated by:

- Cardboard Recyclers • Distribution Centers
- Industrial Parks • Municipalities • Manufacturers
- Pallet Recyclers • Wood Recyclers

With the Sani-Tech auger compactor all you have to do is throw the material into the compactor, turn it on and walk away. When you return, the material will be safely processed into a receiver bin and the compactor will be ready for more.

COST SAVINGS IS THE BOTTOM LINE

**Substantial reductions in operating cost are obtained by:
increased compaction, labor savings and reduced trash pick-ups.**

STATIONARY COMPACTOR MODEL ST4060/36

SPECIFICATIONS

Hopper Capacity:	10 Cubic Yards
Auger Diameter:	Tapered 60" to 36"
Auger RPM:	7.5
Motor:	40 HP
Displacement Rate:	600 cu. yds./hr.
Electrical:	240v/480v - 3 Phase
Amperage:	96a / 48a
Drive:	Electro-mechanical
Control Panel:	UL listed 110 volt
Auger Torque:	780,000 In. Lbs.

Specifications are subject to change without notice to accommodate design improvements.

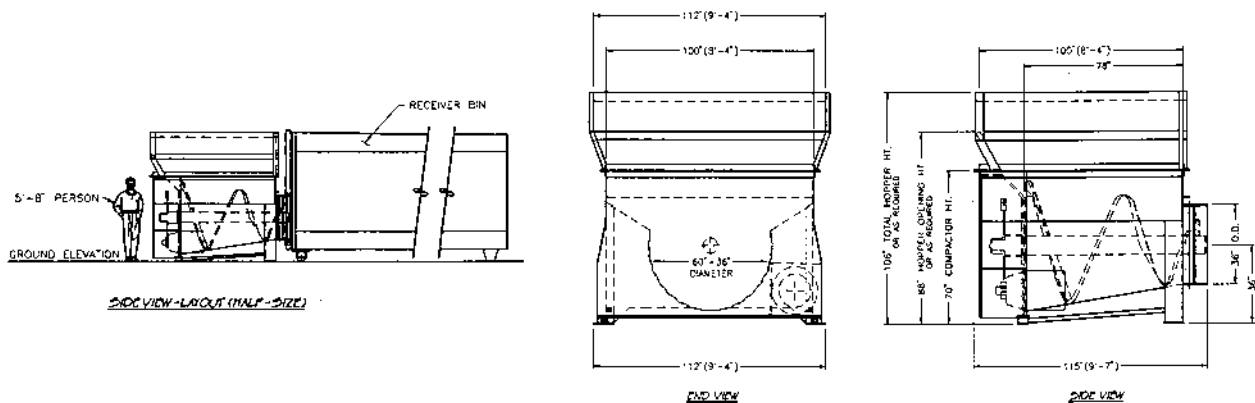

STANDARD FEATURES

- ◆ Abrasion Resistant Alloy Steel Auger
- ◆ Replaceable Cast Auger End Wear Plate
- ◆ Adjustable Running Time
- ◆ Bin Near Full Indicator
- ◆ "Almond" Machinery Enamel Finish
- ◆ Liquid Tight Auger Chamber
- ◆ Adjustable Compaction Density
- ◆ Safety Interlock System
- ◆ Keylock Start/Reverse Switch
- ◆ Mushroom Stop Switch
- ◆ Electric Lubrication System

OPTIONAL FEATURES

- ◆ Odor / Insect Control
- ◆ Cart Dumper
- ◆ Custom Paint Colors
- ◆ Exhaust Fans
- ◆ Fire Suppression Systems
- ◆ Custom Hood Designs
- ◆ Liquid Drain System
- ◆ Bin Gone Sensor
- ◆ Photo Eye Automatic Start

Consult factory for any custom design work.

3hp to 40hp models available for additional applications.



DEALER:

PO. Box 444 Duvall, WA. 98019
(425) 788-6444 Fax: (425) 844-8625
E-Mail: compactorinfo@sanitech.net
Web Site: sanitech.net